

# Fuel System

2. Install the joint rubber (5) and seat it onto the fuel joint as shown. Align the fuel quick connect fitting with the fuel joint. Then press the quick fitting onto the pipe of the fuel joint until both retainer pawls lock with a “click”.

If it is hard to connect, put a small amount of engine oil on the pipe end.

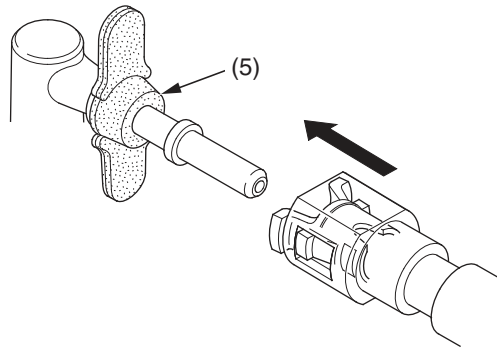

(5) joint rubber (new: injector side only)

3. Make sure the connection is secure and that the pawls are firmly locked into place; check visually and by pulling the connector.
4. Make sure the joint rubber (5) is in place between the flange (6) and retainer tab (7).

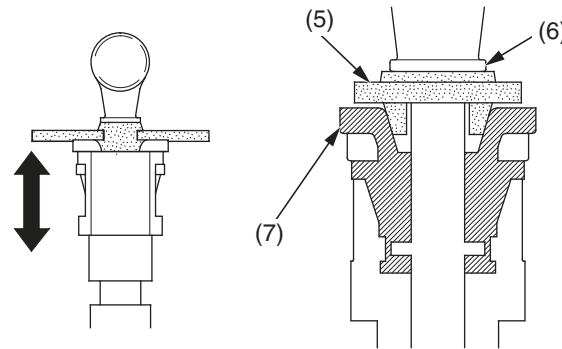

(5) joint rubber (injector side only)  
 (6) flange  
 (7) retainer tab

5. Install the setting rubber (8), clamp (9) and bolt (10) by aligning the clamp tab (11) with the groove (12) of the stay.

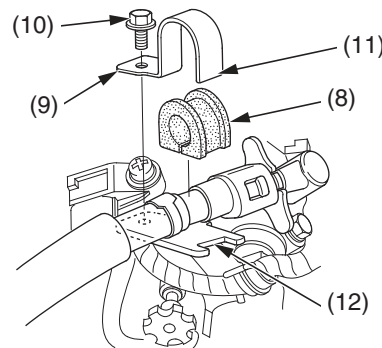

(8) setting rubber  
 (9) clamp  
 (10) bolt  
 (11) clamp tab  
 (12) groove

6. Install the fuel quick connect fitting cover (13) and set the rubber cover tab (14) to the hole (15) of the fuel quick connect fitting cover.

Be sure the rubber cover (16) is properly installed between the fuel quick connect fitting cover and fuel pump.

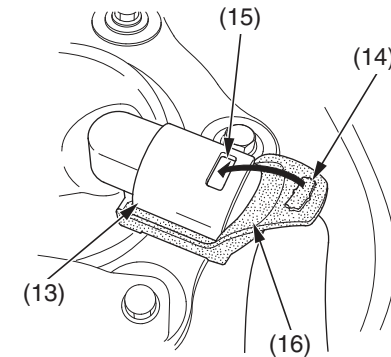

(13) fuel quick connect fitting cover  
 (14) rubber cover tab  
 (15) fuel quick connect fitting cover hole  
 (16) rubber cover

7. Increase the fuel pressure ([page 47](#)).