

Valve Clearance

4. Rotate the crankshaft by turning the primary drive gear bolt (2) clockwise until the punch mark (3) on the primary drive gear aligns with the index mark (4) on the right crankcase cover. In this position, the piston may either be on the compression or exhaust stroke at TDC. If the crankshaft passed the punch mark, rotate the primary drive gear bolt clockwise again and align the punch mark with the index mark. The inspection must be made when the piston is at the top of the compression stroke when both the intake and exhaust valves are closed. This condition can be determined by moving the exhaust rocker arm (5). If it is free, an indication that the valves are closed and that the piston is on the compression stroke. If it is tight and the valves are open, rotate the primary drive gear bolt 360° and realign the punch mark with the index mark.

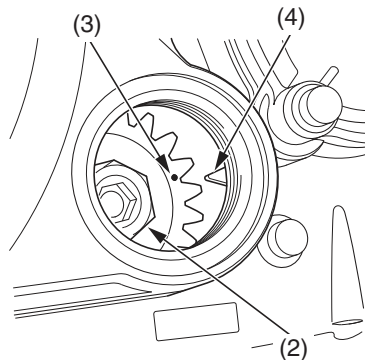

(2) primary drive gear bolt (4) index mark
(3) punch mark



(5) exhaust rocker arm

Valve Clearance Inspection

1. Set the piston at TDC on the compression stroke ([page 67](#)).
2. Measure the intake valve clearance by inserting a feeler gauge (1) between the valve lifters (2) and intake cam lobes (3).

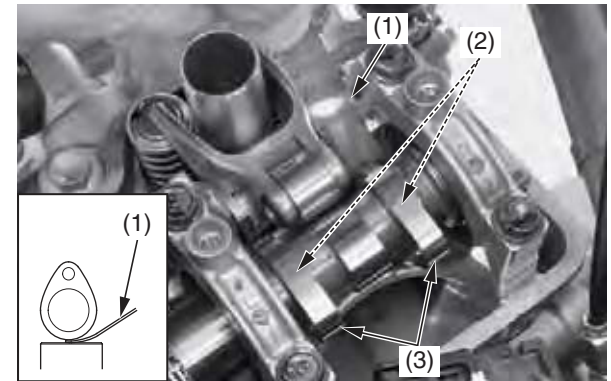

- (1) feeler gauge
(2) valve lifters
(3) intake cam lobes

Valve Clearance:
IN: 0.005 ± 0.001 in (0.12 ± 0.03 mm)