

## RIDING

### WARNING

- \* *Review ATC Safety (page 1) before you ride.*
- \* *Avoid “wheelies” and “jumping” as they may cause loss of control.*
- \* *Ride with both feet on the footpegs at all times. If your feet are off the footpegs and touch the ground while the ATC is moving, they may come in contact with the rear wheels, causing injury.*

Under normal riding conditions it is not necessary or desirable to touch the ground for balance.

For your initial riding practice, select a safe area free of obstacles and with an even surface. Avoid paved surfaces as they make learning to maneuver more difficult, and will also significantly shorten tire life.

1. After the engine has been warmed up, release the parking brake. The ATC is ready for riding.
2. While the engine is idling, pull in the clutch lever and depress the gearshift pedal to shift into 1st (low) gear.
3. Gradually release the clutch lever as you increase engine speed by opening the throttle.
4. When the speed increases, close the throttle, pull in the clutch lever, and shift to 2nd gear by raising the gearshift pedal.

5. This sequence is repeated to progressively shift up to 3rd, 4th and 5th (top) gear.

### CAUTION:

- \* *Do not shift gears without disengaging the clutch and closing the throttle. The engine and drive train could be damaged by overspeed and shock.*
- \* *Do not tow the vehicle or coast for long distances while the engine is OFF. The transmission will not be properly lubricated and damage may result.*

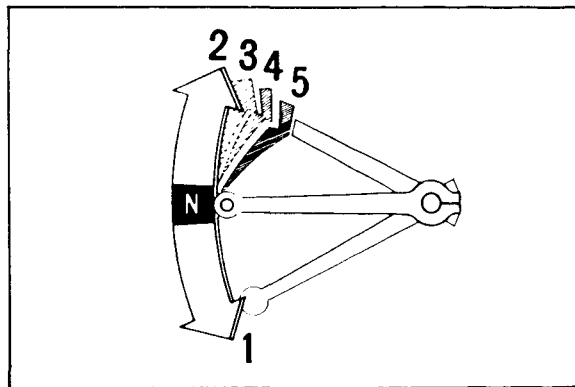

Shifting pattern