

## ENGINE OIL AND FILTER

Engine oil should be changed in accordance with the maintenance schedule. Use motor oils of the grade and viscosity recommended on Page 23.

When changing oil, drain the oil from the crankcase while the engine is still warm. This will ensure complete and rapid draining.

1. With the ATC on level ground, remove the oil filler cap from the right crankcase cover.
2. Place an oil drain pan under the crankcase and remove the oil drain plug (1).
3. Remove the oil filter cover by removing the bolts. Let the remaining oil drain out. Discard the oil filter (2).
4. Check that the oil filter cover O-ring (3) is in good condition and then install the new oil filter with the rubber on oil filter facing out and install the cover using the bolts. Tighten the bolts securely.

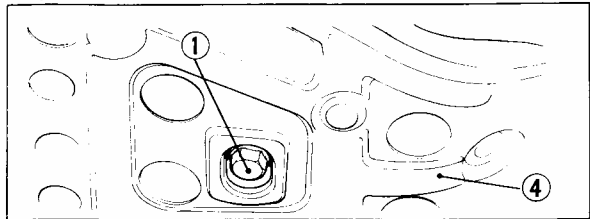

(1) Oil drain plug

(4) Engine under guard

5. Reinstall the drain plug securely and fill the crankcase with approximately 2.1 liters (2.2 US qt) of the recommended oil.
6. Reinstall the oil filler cap.
7. Start the engine and let it idle for 2–3 minutes.
8. Stop the engine and make sure that oil level is between the upper and lower marks on the dipstick. If necessary, add more oil but do not overfill.

### CAUTION

\* *Running the engine with improper oil level can cause serious engine damage.*

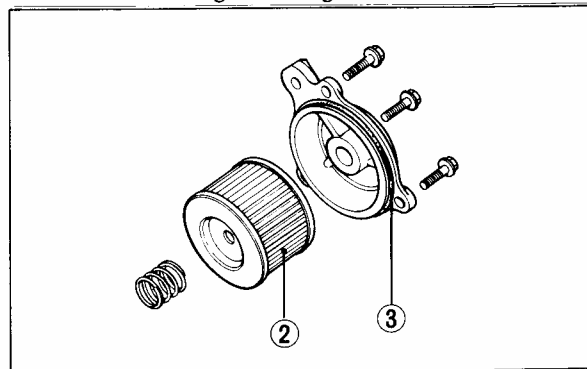

(2) Oil filter

(3) O-ring