

## REAR SUSPENSION

The ATC250R's shock absorber has three adjustments: spring preload, rebound damping and compression damping. In addition, the lower shock absorber mount utilizes the Pro-Link system to deliver true progressive springing and damping rates. Through these features, the shock can be adjusted to suit the rider's weight and riding conditions.

### NOTE:

\* All three adjustments should be made together, according to the sequence shown on pages 20 through 22.

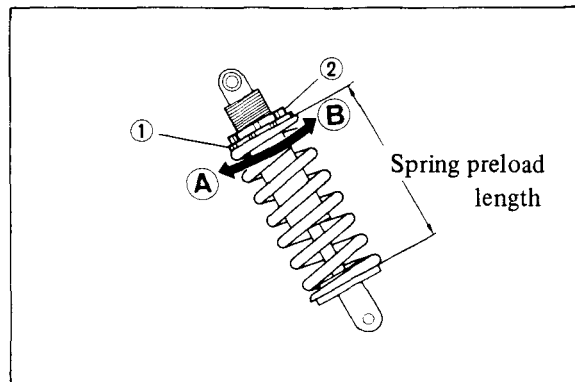

(1) Adjust nut

(2) Lock nut

(A) Increase

(B) Decrease