

Spring Preload:

The spring preload adjuster (1) has 7 spring preload positions for different load or riding conditions.

Remove the right side cover (page 57).

Use the pin spanner (2) and extension bar (3) to adjust the rear shock.

Position 1 is for a light load and smooth road conditions. Position 2 is the standard position. Positions 3 to 7 increase spring preload for a stiffer rear suspension and can be used when the motorcycle is more heavily loaded.

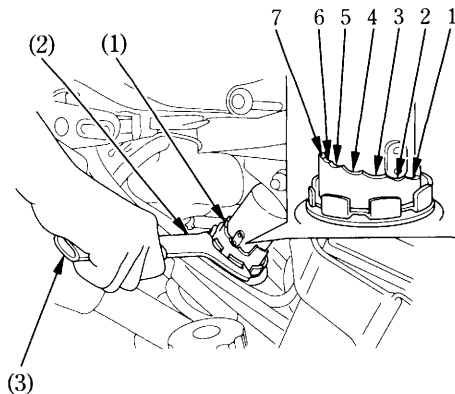

- (1) Spring adjuster
- (2) Pin spanner
- (3) Extension bar