

Installation:

1. Position the front wheel between the fork legs and insert the front axle from the left side, through the left fork leg and wheel hub.
 2. Align the index line (6) of the front axle shaft with the surface (7) of fork leg.
 3. Tighten the front axle pinch bolts on the left fork leg to the specified torque:
22 N·m (2.2 kgf·m , 16 lbf·ft)
 4. Tighten the axle bolt to the specified torque:
59 N·m (6.0 kgf·m , 43 lbf·ft)
 5. Install the right and left caliper assemblies to the fork legs and tighten the fixing bolts to the specified torque:
30 N·m (3.1 kgf·m , 22 lbf·ft)
- To avoid damaging the brake pads while installing the caliper assemblies, carefully fit both brake discs between the pads.

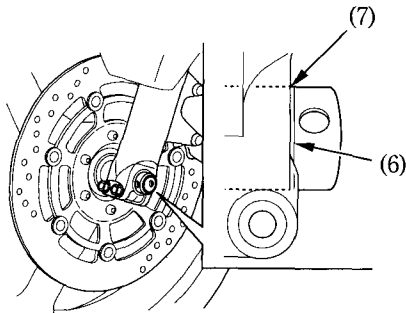

- (6) Index line
(7) Surface