

11. Install the spark plug (page 55).
12. Coat a new O-ring (19) with oil and install it onto the crankshaft hole cap (20).
Apply grease to the crankshaft hole cap threads.
Install and tighten the crankshaft hole cap to the specified torque:
15 N·m (1.5 kgf·m, 11 lbf·ft)

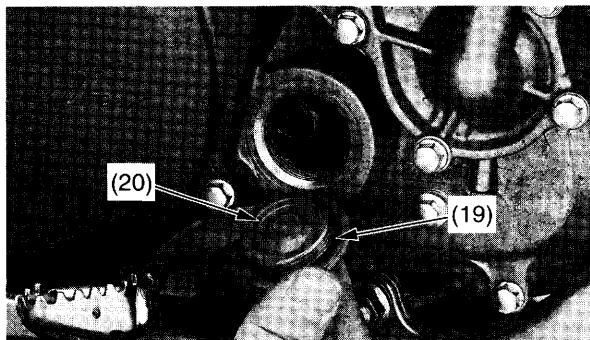

(19) O-ring
(20) crankshaft hole cap

Cylinder Head Cover Installation

1. Check the spark plug hole packing (1) is in good condition, replace it if necessary.
Install the spark plug hole packing to the spark plug hole (2).

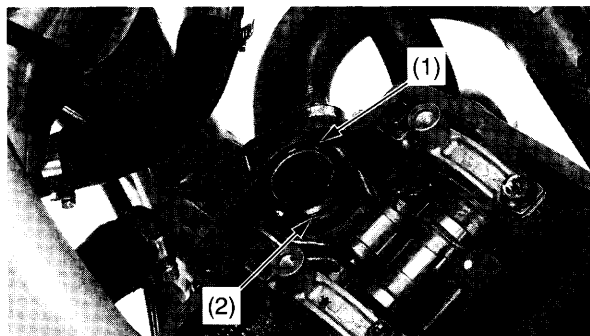

(1) spark plug hole packing
(2) spark plug hole

2. Inspect the cylinder head cover packing (3) for damage or deterioration, replace it if necessary.
Install the cylinder head cover packing into the groove of the cylinder head cover (4).

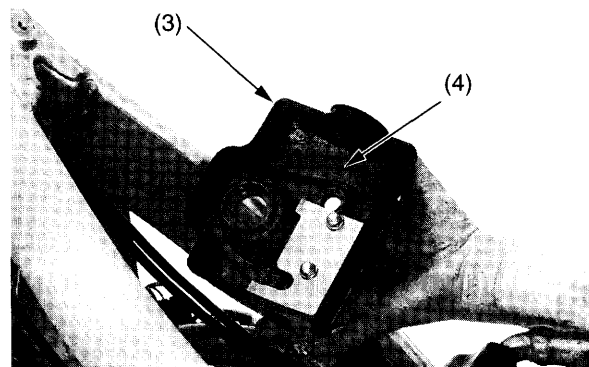

(3) cylinder head cover packing
(4) cylinder head cover

3. Check the rubber seals (5) are in good condition, replace them if necessary.
Install the rubber seals onto the cylinder head cover with the "UP" marks (6) facing up.

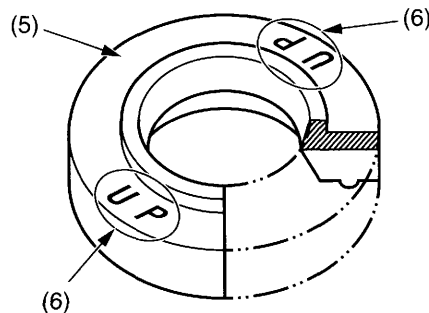

(5) rubber seal
(6) "UP" marks

4. Install the cylinder head cover (4) and tighten the cylinder head cover bolts (7) to the specified torque:
10 N·m (1.0 kgf·m, 7 lbf·ft)

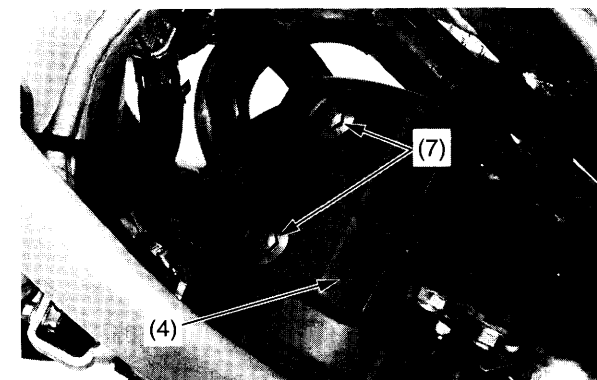

(4) cylinder head cover
(7) cylinder head cover bolts

5. Connect the direct ignition coil (8) and breather tube (9).

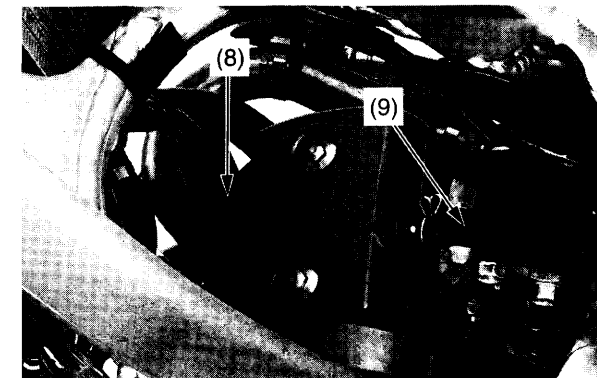

(8) direct ignition coil
(9) breather tube

6. Install the fuel tank and the seat (pages 29, 31).