

Front Suspension Adjustments

14. Install a new O-ring (13) on the fork damper assembly (4). Apply the recommended fork oil to the O-ring.
15. Pull up the fork assembly (1) slowly and install the fork damper assembly (4) into the outer tube.

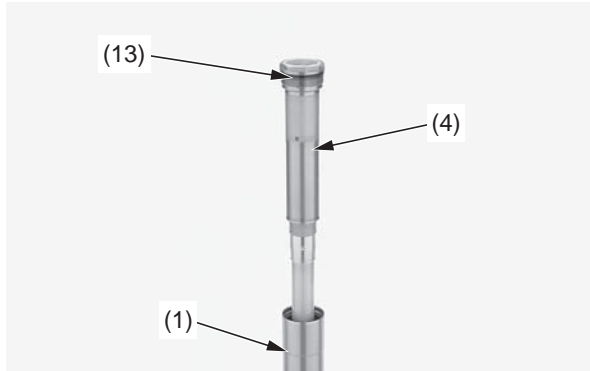

(1) fork assembly (13) O-ring
(4) fork damper assembly

16. Insert both fork legs into the fork clamps. Tighten the fork bridge lower pinch bolts (14) to the specified torque:
20 N·m (2.0 kgf·m, 15 lbf·ft)

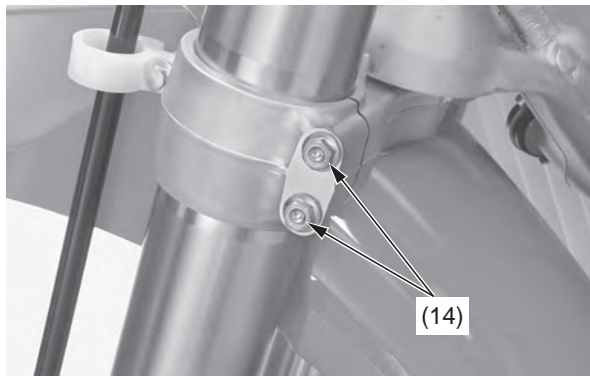

(14) fork bridge lower pinch bolts

17. Tighten the fork damper (15) to the specified torque using the lock nut wrench (16).
Actual:
30 N·m (3.1 kgf·m, 22 lbf·ft)
Torque wrench scale reading:
27 N·m (2.8 kgf·m, 20 lbf·ft), using a 50 cm (20 in) long deflecting beam type torque wrench.

- Lock nut wrench 070MA-MEN0100

When using the lock nut wrench, use a 50 cm (20 in) long deflecting beam type torque wrench. The lock nut wrench increases the torque wrench's leverage, so the torque wrench reading will be less than the torque actually applied to the fork damper.

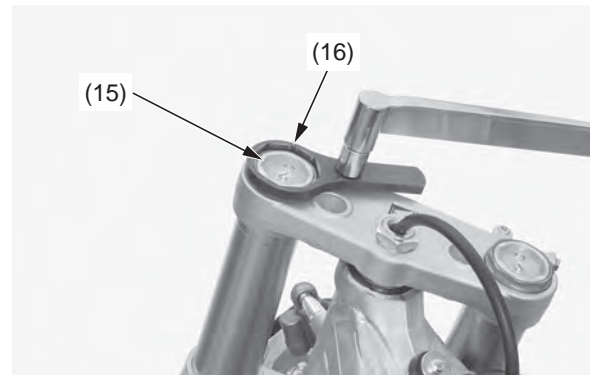

(15) fork damper (16) lock nut wrench

18. For ease of releasing air pressure after the forks are installed, loosen the fork bridge lower pinch bolts and position the outer tubes so that the fork air pressure release screws are in front of the compression damping adjusters. Align the top of the outer tube (17) with the top surface of the top bridge (18).

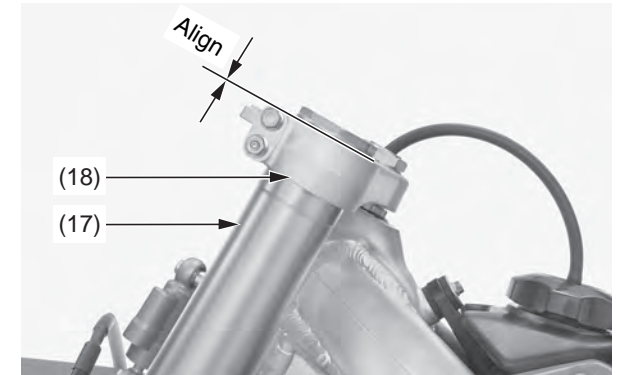

(17) outer tube (18) top bridge

19. Tighten the fork bridge lower pinch bolts (14) to the specified torque:
20 N·m (2.0 kgf·m, 15 lbf·ft)
20. Tighten the fork bridge upper pinch bolts (19) to the specified torque:
22 N·m (2.2 kgf·m, 16 lbf·ft)

NOTICE

Over-tightening the pinch bolts can deform the outer tubes. Deformed outer tubes must be replaced.

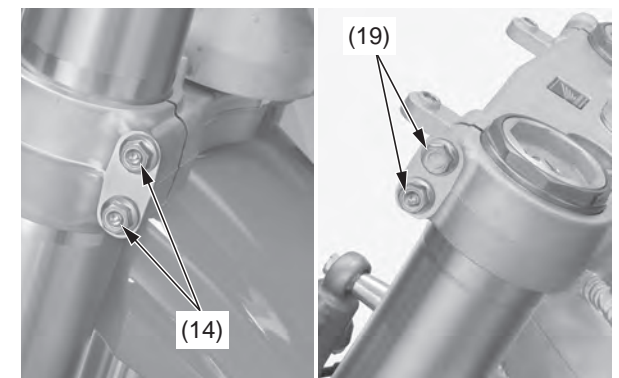

(14) fork bridge lower pinch bolts
(19) fork bridge upper pinch bolts

(cont'd)