

Rear Brake

Adjustment:

1. Place the motorcycle on its center stand.
2. Measure the distance the rear brake pedal (1) moves before the brake starts to take hold.

Freeplay should be:

20–30 mm (0.8–1.2 in)

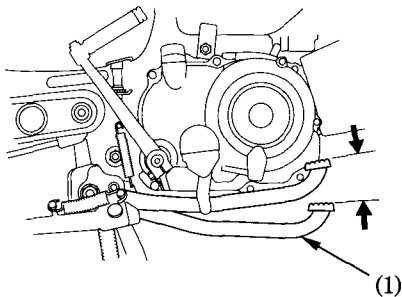

(1) Rear brake pedal

3. If adjustment is necessary, turn the rear brake adjusting nut (2).

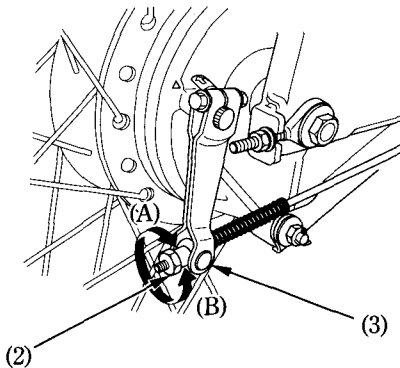

- (2) Rear brake adjusting nut
- (3) Brake arm pin
- (A) Decrease free play
- (B) Increase free play