

If you cannot restart a warm engine:

1. Place the scooter on its center stand and lock the rear brake lever.
2. Open the throttle (1)  $1/8$  -  $1/4$  turn while starting the engine.

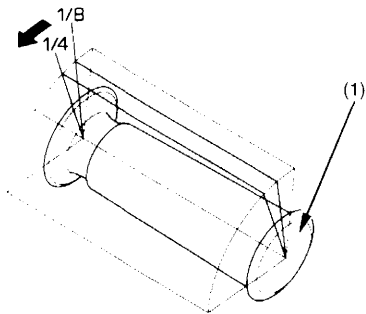

(1) Throttle

## **RUNNING IN**

Help assure your scooter's future reliability and performance by paying extra attention to how you ride for the first 500 km (300 miles). Do not exceed 80% of the machine's maximum allowed speed.

Avoid opening the throttle fully and maintaining the same speed for a long period. During the early running in period the new machined surfaces are in contact with each other and can wear quickly. The servicing 1,000 km after running in is to compensate for this initial wear. If you run your scooter in carefully you will ensure a long life and excellent performance from the engine.