

Spring preload adjustment:

The spring preload adjuster has 6 spring preload positions for different load or riding conditions.

To make adjustments, turn the adjuster knob (1) clockwise to increase and counterclockwise to decrease preload. Align the lip of the adjuster (2) to any of the six segments according to the following recommended adjustments for various loads.

Vehicle load	Damping Force	Spring preload
Rider alone (up to 75 kg)	1	1 to 3
Rider + Cargo (up to 100 kg)	2	4
Rider + Passenger (up to 150 kg)	2	4 to 5
Rider + Passenger + Cargo (up to Max. Weight Capacity)	3	6

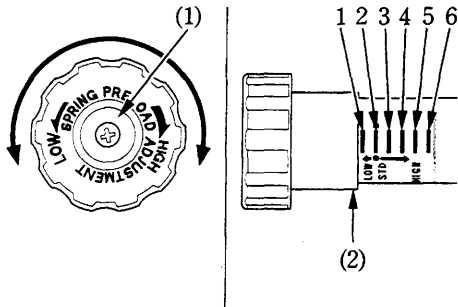

(1) Adjuster knob

(2) Adjuster lip