

---

### Installation:

#### 1. Reassemble the removed parts in the reverse order of removal.

- Position the wheel between the fork legs and insert the front axle shaft from the left side, through the left fork leg and wheel hub.
- Align the end of axle shaft with the surface of fork leg.
- Fit the brake disc carefully between the brake pads to avoid damaging the pads.

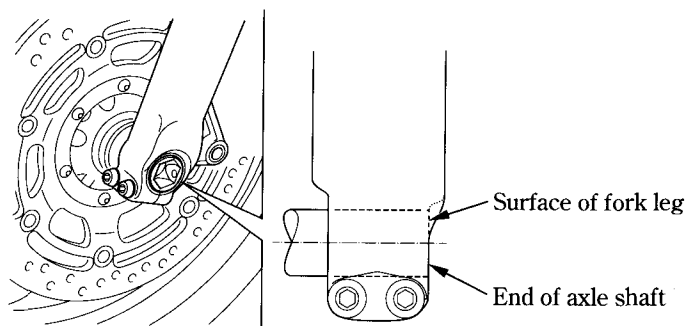

#### 2. Install the bolts and tighten to the specified torque:

axle bolt:

79 N·m (8.1 kgf·m , 58 lbf·ft)

right caliper fixing bolts:

31 N·m (3.2 kgf·m , 23 lbf·ft)

left caliper socket bolts:

31 N·m (3.2 kgf·m , 23 lbf·ft)