

2. Remove the brake shoe lining inspection hole cap (2) and inspect the lining thickness.

**Lining Thickness:**

Standard: 4.0 mm (0.16 in)

Service Limit: 2.0 mm (0.08 in)

**NOTE:**

- \* If either lining is worn beyond the limit, both brake shoes must be replaced.
3. If the brake lever free play is excessive and the brake linings are not worn beyond the recommended limit, adjust the brake shoe lining-to-drum clearance.

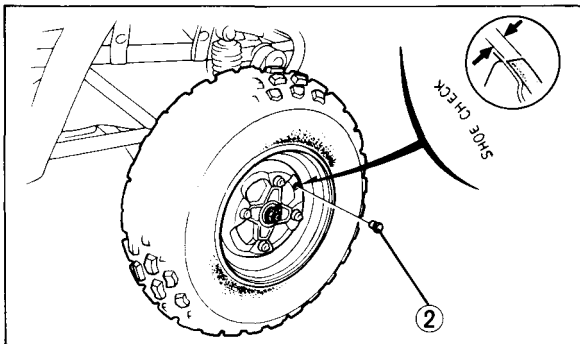

(2) Lining inspection hole cap

4. Recheck the brake lever free play. If free play is still excessive after adjusting the brake lining clearance, there is probably air in the brake system and it must be bled out. See your authorized Honda dealer for this service.

**Adjustment:**

1. Pump the brake lever 2-3 times firmly and release it.
2. Remove the adjusting hole cap (1).
3. Turn the both brake shoe adjusters (2) up with a screwdriver until the front brake locks.

**NOTE:**

- \* Do not work on both adjusters at the same time.

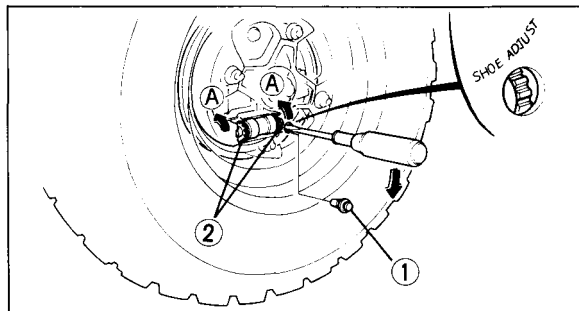

(1) Adjustment hole cap (2) Adjusters  
(A) Brake locks