

Main Fuse:

The main fuse (1) is located behind the rear cowl.

The specified fuse is:

30 A

1. Remove the rear cowl (page 57).
2. Disconnect the wire connector (2) of the starter magnetic switch.
3. Pull out the old fuse and install a new fuse.
The spare fuse (3) is located under the starter magnetic switch.
4. Reconnect the connector and install the rear cowl.

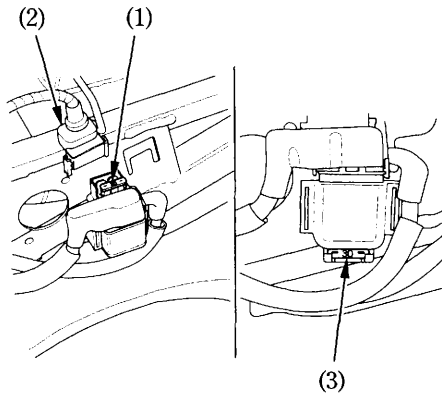

(1) Main fuse
(2) Wire connector

(3) Spare main fuse