

Frame servicing

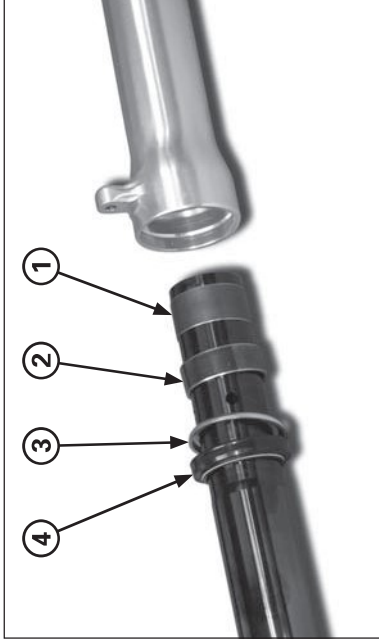

- (1) FORK TUBE BUSHING
- (2) GUIDE BUSHING
- (3) BACK-UP RING
- (4) OIL SEAL

Right Fork Assembly

Clean the parts thoroughly with non-flammable or high flash point solvent before assembly.

Install the following:

- Fork tube bushing
- Guide bushing
- Back-up ring
- New oil seal

Coat the guide and fork tube bushings with recommended fork fluid.

Install the fork tube assembly into the fork slider.

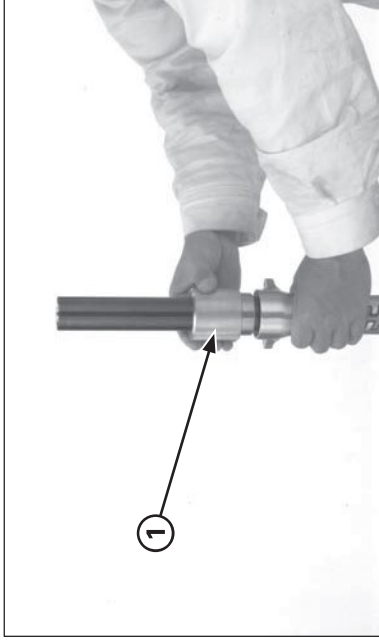

- (1) FORK SEAL DRIVER

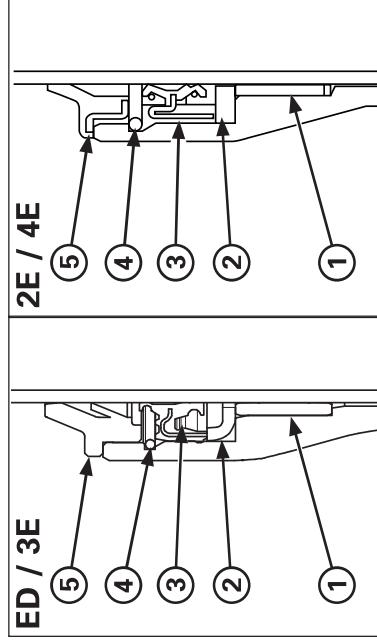

- (1) GUIDE BUSHING
- (2) BUCK-UP RING
- (3) OIL SEAL
- (4) STOP RING
- (5) DUST SEAL

Drive the guide bushing, back-up ring and oil seal until the stop ring groove is visible, using the special tool.

Tool:

Fork seal driver

07947-4630100

Install the stop ring into the fork slider groove securely. Install the dust seal.

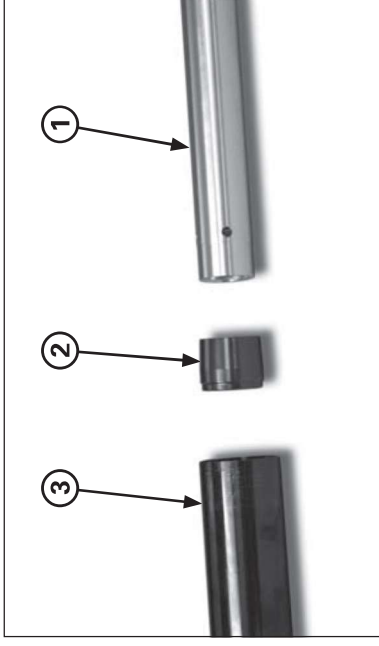

- (1) FORK DAMPER ASSEMBLY
- (2) CENTERING PLATE
- (3) FORK TUBE

Install the centering plate and fork damper assembly into the fork tube.