

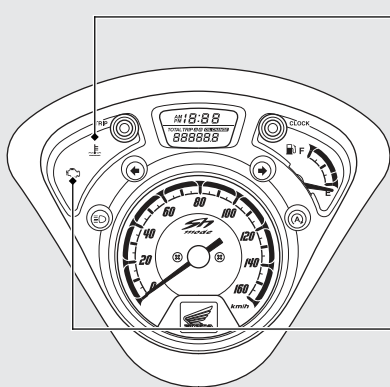

Spie

Se alcune non si accendono quando dovrebbero, fare controllare il problema presso la concessionaria.



 **Spia alta temperatura liquido di raffreddamento**

Se la spia si accende durante la guida:

 **P.87**

 **Spia guasti PGM-FI (iniezione programmata del carburante) (MIL)**

La spia si accende quando il commutatore di accensione viene portato in posizione  (On).

Se la spia si accende con il motore in funzione:  **P.88**