

## Drive Chain ► Inspecting the Drive Chain Slack

4. Move the drive chain up and down with your finger.

### Drive chain slack:

1.0 - 1.4 in (25 - 35 mm)

- Do not ride your vehicle if the slack exceeds 1 15/16 in (50 mm).

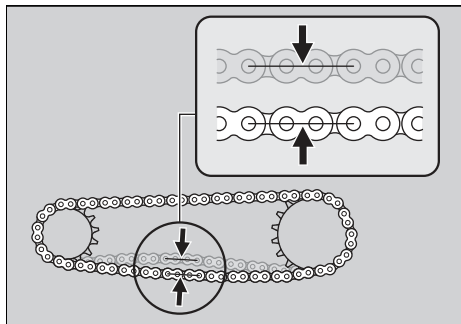

5. Rotate the rear wheel and check that the chain moves smoothly.

6. Remove the chain covers by removing the bolts.

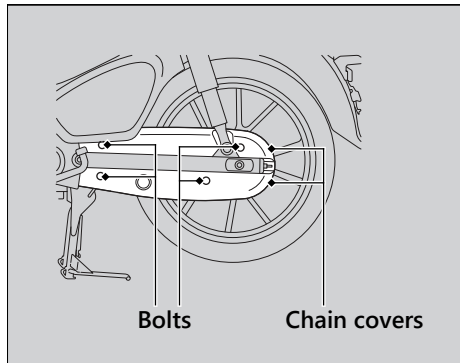

7. Inspect the sprockets. ► P. 68
8. Clean and lubricate the drive chain. ► P. 69
9. Install the parts in the reverse order of removal.
10. Tighten the bolts.

**Torque:** 5.2 lbf-ft (7 N·m, 0.7 kgf·m)