

Air Cleaner ► Changing Air Cleaner Element

4. Remove the air cleaner duct and air cleaner case cover/element by removing the screws A.

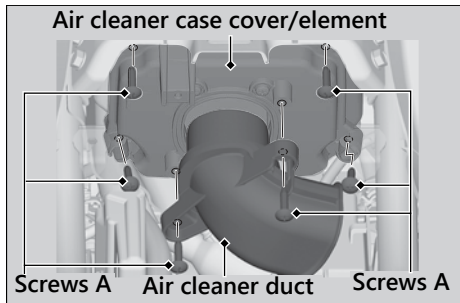

5. Remove the air cleaner element from the air cleaner case cover by removing the screws B.

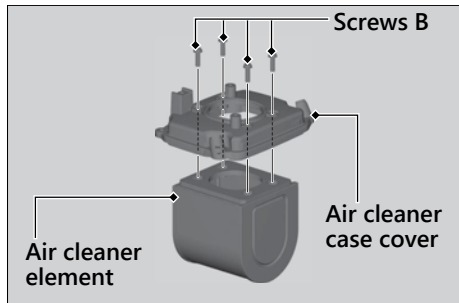

6. Install the new air cleaner element.
► Make sure the air cleaner element is installed securely.
7. Install the parts in the reverse order of removal.
► Tighten the screws A.

Torque: 0.8 lbf·ft (1.1 N·m, 0.1 kgf·m)