

Refer to *Safety Precautions* on page 19.

The air cleaner uses polyurethane inner and outer pieces which can't be separated. A dirty air cleaner will reduce engine power.

Proper air cleaner maintenance is very important for off-road vehicles. A dirty, water-soaked, worn-out, or defective air cleaner will allow dirt, dust, mud, and other impurities to pass into the engine.

Service the air cleaner more frequently if you ride in unusually wet or dusty areas. Your dealer can help you determine the correct service interval for your riding conditions.

Your CRF's air cleaner has very specific performance requirements. Use a new Honda Genuine air cleaner specified for your model or an air cleaner of equal quality.

NOTICE

Using the wrong air cleaner may result in premature engine wear.

Proper air cleaner maintenance can prevent premature engine wear or damage, expensive repairs, low engine power, poor gas mileage, and spark plug fouling.

NOTICE

Improper or lack of proper air cleaner maintenance can cause poor performance and premature engine wear.

Cleaning

1. Remove the seat (page 29).
2. Remove the air cleaner retaining bolt (1) and air cleaner assembly (2).

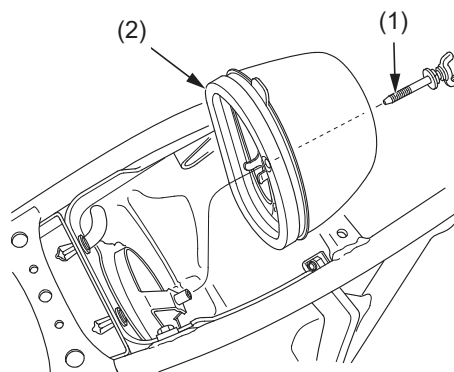

- (1) air cleaner retaining bolt
(2) air cleaner assembly

3. Remove the air cleaner element (3) from the air cleaner holder (4).

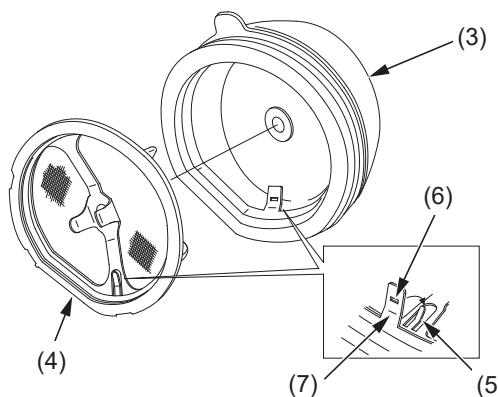

- (3) air cleaner element
(4) air cleaner holder
(5) holder tab
(6) hole
(7) air cleaner tab

4. Wash the air cleaner element in clean non-flammable cleaning solvent. Then wash in hot, soapy water, rinse well, and allow to dry thoroughly.

The air cleaner element is made in two pieces: inner and outer, which cannot be separated.

5. Clean the inside of the air cleaner housing.
6. Allow the air cleaner to dry thoroughly. After drying, apply 1.7 US oz (50 cm³) of clean Pro Honda Foam Filter Oil or an equivalent air cleaner oil from the inside of the element. Place the element into a plastic bag and spread the oil evenly by hand.

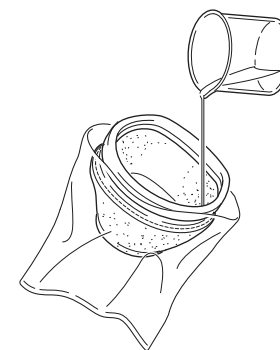

7. Apply 0.09 – 0.11 oz (2.6 – 3.0 g) of Pro Honda White Lithium Grease or equivalent to the air cleaner housing contact area of the air cleaner element.
8. Assemble the air cleaner element and holder. Install the holder tab (5) in the hole (6) of the air cleaner tab (7).

(cont'd)