

Right Fork Disassembly

- If your CRF is brand-new, put enough part-throttle break-in time (about 1 hour) on it to ensure that the suspension has worked in.
- When disassembling the fork, turn the compression (1) and rebound (2) damping adjusters counterclockwise to the softest position to prevent damaging the adjustment needle (be sure to record the number of turns from the starting position).

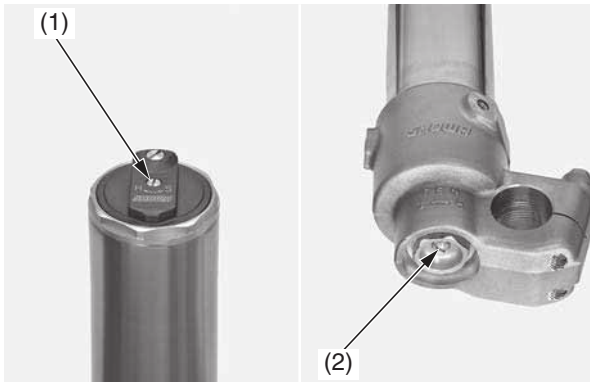

(1) compression damping adjuster
(2) rebound damping adjuster

1. Remove the fork protector socket bolts (3) and fork protector (4).

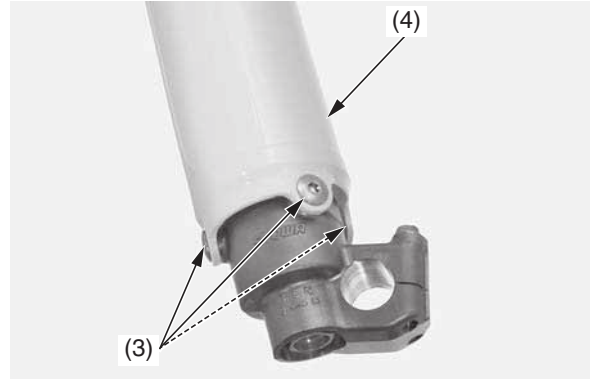

(3) fork protector socket bolts
(4) fork protector

2. Hold the outer tube, then remove the fork damper (5) from the outer tube using a lock nut wrench (6). Gently slide the outer tube down onto the lower end (axle holder) (7).

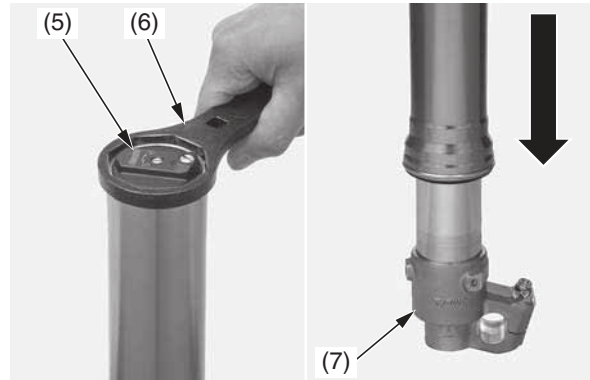

(5) fork damper
(6) lock nut wrench
(7) axle holder

NOTICE

The outer tube (8) can drop on the slider (9) and damage the fork dust seal (10). To avoid damage, hold both the outer tube and slider when removing the fork damper.

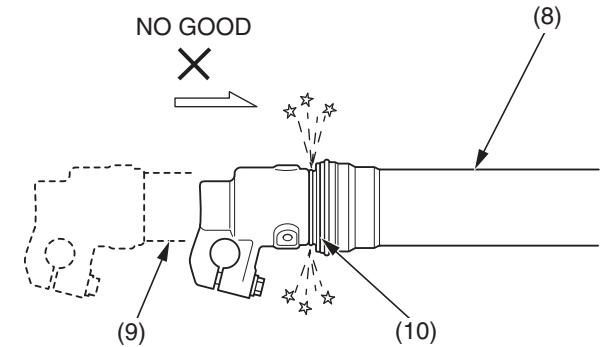

(8) outer tube
(9) slider
(10) fork dust seal

3. Drain the fork oil from the outer tube/slider (11) and oil holes (12) of the fork damper.
4. Temporarily install the fork damper (5) to the outer tube.

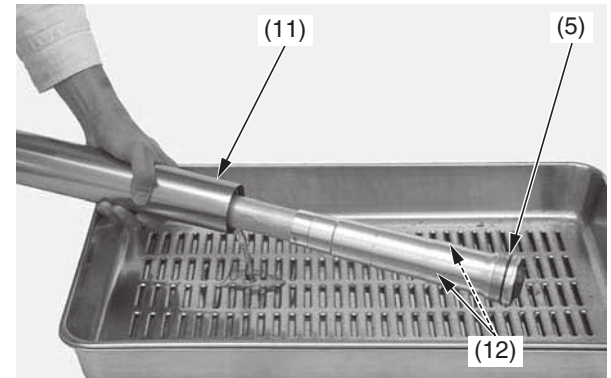

(5) fork damper
(11) outer tube/slider
(12) oil holes

(cont'd)