

7. Unlock the slide retainer (8) of the quick connect fitting by completely pulling it up. Release the fuel quick connect fitting from the fuel joint (9) while holding the connector housing (10).
 - Use a shop towel to absorb the remaining fuel in the fuel feed hose.
 - Be careful not to damage the hose or other parts.
 - Do not use tools.
 - Dirt intruding into the connector housing may cause slide retainer sticking.

⚠ WARNING

Gasoline is highly flammable and explosive. You can be burned or seriously injured when handling fuel.

- Stop the engine and keep heat, sparks and flame away.
- Handle fuel only outdoors.
- Wipe up spills immediately.

Injector side:

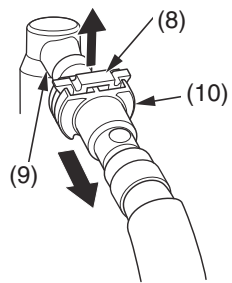

Fuel pump side:

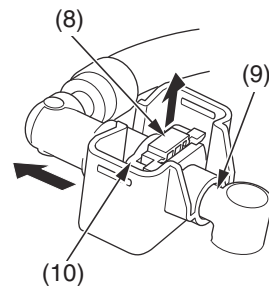

- (8) slide retainer
 (9) fuel joint
 (10) connector housing

8. Remove the rubber cover (11) from the fuel joint of the fuel pump.

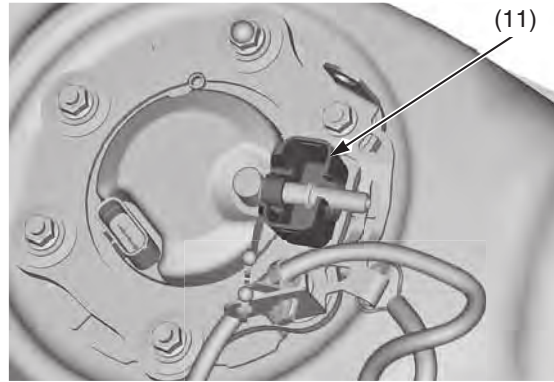

(11) rubber cover

9. To prevent damage and keep foreign matter out, cover the disconnected connector (12) and fuel joint (9) with plastic bags (13).

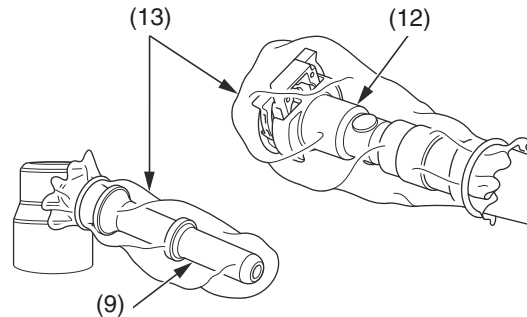

- (9) fuel joint
 (12) disconnected connector
 (13) plastic bags

Connection

1. Install the rubber cover (1) onto the fuel joint (2) of the fuel pump as shown.

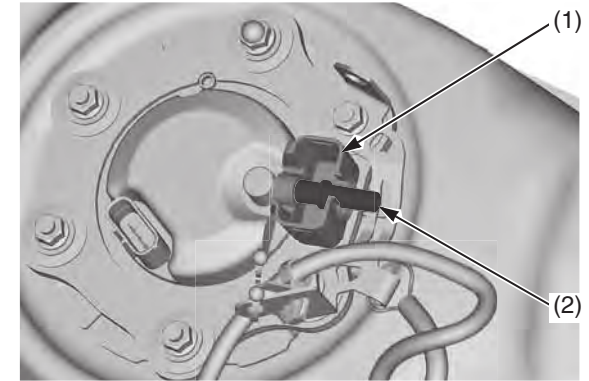

(1) rubber cover
 (2) fuel joint

2. Be sure that the slide retainer (3) is completely pulled up before connecting the quick connect fitting.
 - Do not bend or twist the fuel feed hose.
 - Do not reuse the kinked or damaged fuel hose.
 - Do not use gloves or a shop towel while installing the quick connect fitting.

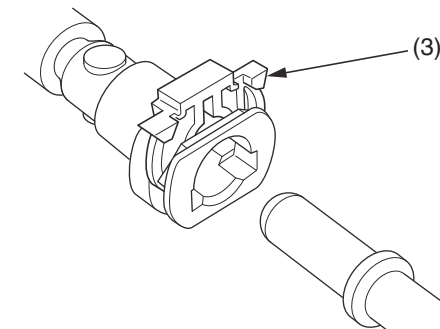

(3) slide retainer

(cont'd)