

8. Install the push rod (14) into the piston rod (15) until it stops.

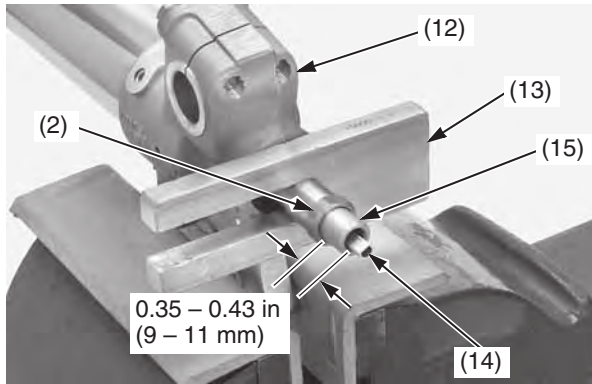

(2) fork center bolt lock nut (14) push rod
(12) axle holder (15) piston rod
(13) piston base

9. Apply fork oil to a new O-ring (16) and install it to the fork center bolt (17).
Install the fork center bolt to the fork damper piston rod (15) by aligning the each flat-side of the fork center bolt adjusting piston rod and push rod (14).
Tighten the fork center bolt fully by hand.

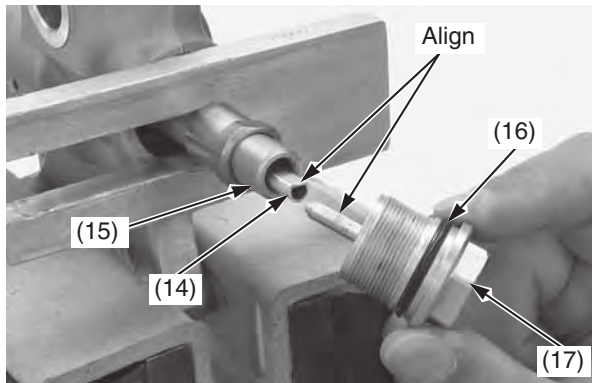

(14) push rod (16) O-ring (new)
(15) piston rod (17) fork center bolt

10. Measure the clearance between the fork center bolt lock nut (2) and fork center bolt (17).
Standard: 0.06 - 0.08 in (1.5 - 2.0 mm)

If the clearance is out of specification, check the fork center bolt lock nut and fork center bolt installation.

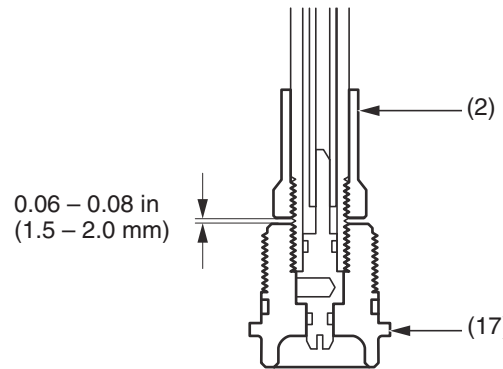

(2) fork center bolt lock nut (17) fork center bolt

11. Tighten the fork center bolt lock nut (2) to the fork center bolt (17) closely by hand. Tighten the fork center bolt lock nut to the specified torque:
21 lbf-ft (28 N-m, 2.9 kgf-m)

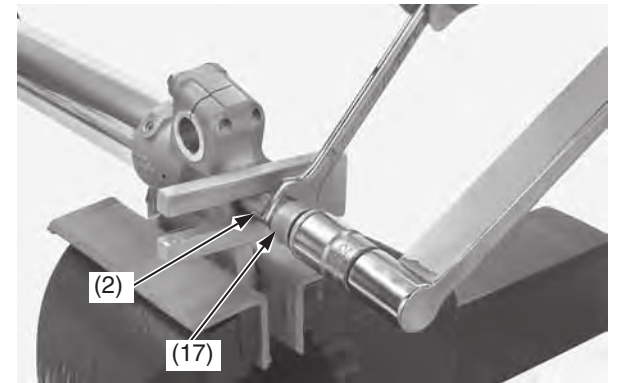

(2) fork center bolt lock nut
(17) fork center bolt

12. Apply locking agent to the fork center bolt threads.
Remove the piston base or mechanic's stopper tool while pushing the fork damper.
Install the fork center bolt (17) to the axle holder and tighten it to the specified torque:
51 lbf-ft (69 N-m, 7.0 kgf-m)

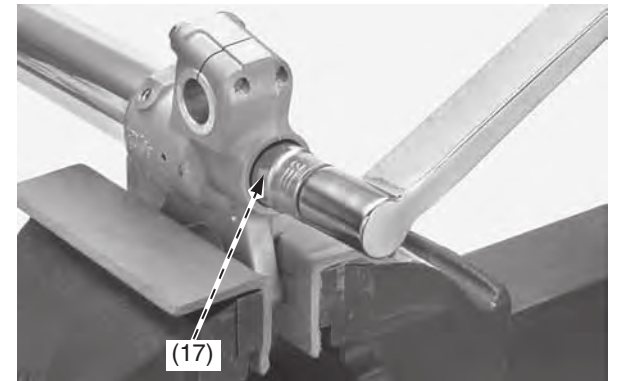

(17) fork center bolt

(cont'd)