

4. Wash the air cleaner in clean non-flammable cleaning solvent such as Pro Honda Foam Air Filter Cleaner. Then wash in hot, soapy water, rinse well, and allow to dry thoroughly. The air cleaner element is made in two pieces: inner and outer, which cannot be separated.
5. Clean the inside of the air cleaner housing.
6. Allow the air cleaner to dry thoroughly. After drying, apply 1.5 US oz (44 cm<sup>3</sup>) of clean Pro Honda Foam Air Filter Oil or an equivalent air cleaner oil from the inside of the element. Place the element into a plastic bag (7) and spread the oil evenly by hand.

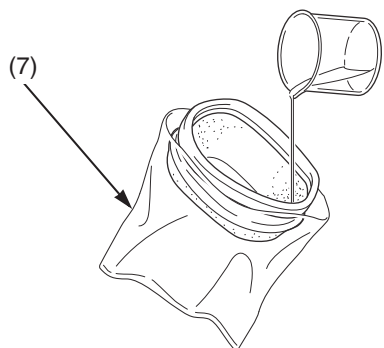

(7) plastic bag

7. Assemble the air cleaner element and holder. Install the holder tab in the hole of the air cleaner element.
8. Apply 0.05 – 0.19 oz (1.5 – 5.5 g) of Pro Honda Foam Air Filter Sealer or equivalent to the air cleaner element contact area of the air cleaner housing.
9. Install the air cleaner assembly (2) into the air cleaner housing stay (8) with the “UP” mark tab (9) facing up.
10. Carefully position the sealing flange of the element to prevent dirt intrusion.

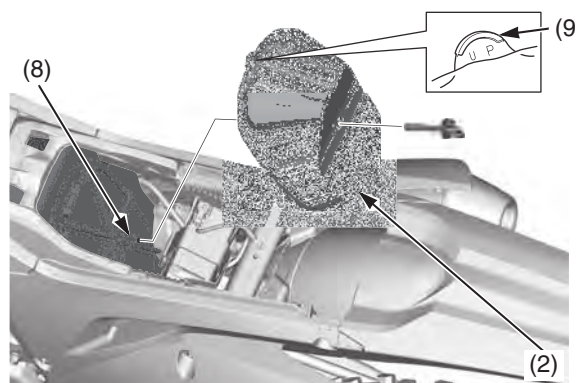

(2) air cleaner assembly  
(8) air cleaner housing stay  
(9) “UP” mark tab

11. Install and tighten the air cleaner retaining bolt (1) to the specified torque:  
1.8 lbf·ft (2.4 N·m, 0.2 kgf·m)

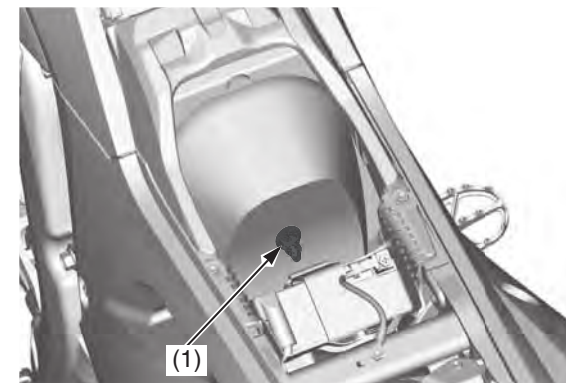

(1) air cleaner retaining bolt

## NOTICE

*Improper installation of the air cleaner assembly may allow dirt and dust to enter the engine and cause rapid wear of the piston rings and cylinder.*

12. Install the seat (page 33).