

Drive Chain

Drive Chain Sliders

1. Check the chain slider (1) for wear.
If the wear is 5 mm (0.2 in) or more, replace it.

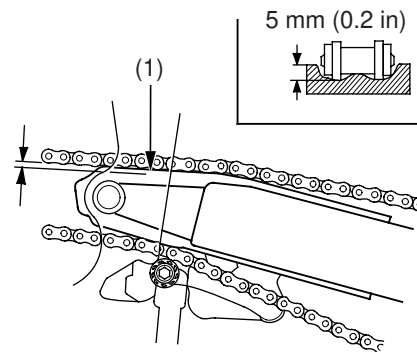

(1) chain slider

2. Check the chain guide slider (2) for wear.
Replace the chain guide slider if it is worn to the bottom of the wear limit groove (3).

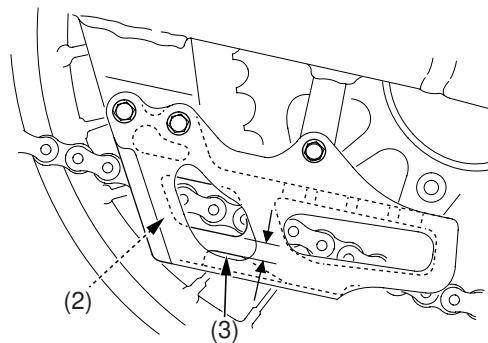
(2) chain guide slider
(3) wear limit groove

Drive Chain Rollers

1. Measure the diameter of the drive chain rollers. Replace them if below the service limit.

Service Limit:

UPPER ROLLER: 39 mm (1.5 in)

LOWER ROLLER: 35 mm (1.4 in)

2. Replace the roller if necessary as follows:
Install the upper drive chain roller (Green) (1) with the “→” mark (2) facing toward the frame and lower drive chain roller (Black) (3) with the “→” mark side facing out.
Tighten the drive chain roller bolt and nut to the specified torque:

Upper roller bolt:

12 N·m (1.2 kgf·m, 9 lbf·ft)

Lower roller nut:

12 N·m (1.2 kgf·m, 9 lbf·ft)

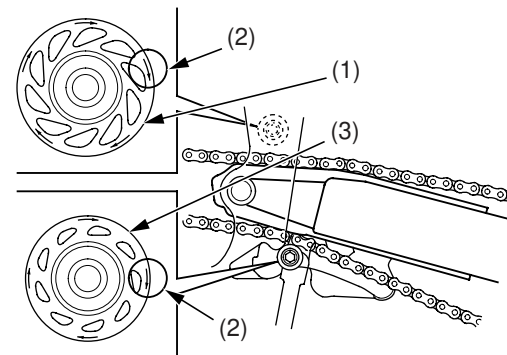
(1) upper drive chain roller (3) lower drive chain roller
(2) “→” mark

Lubrication

Lubricate the drive chain with #80 – 90 gear oil or drive chain lubricant designed specifically for use with O-ring chains. Wipe off the excess oil or chain lubricant.

