

### Checking the Final Drive Oil

1. Hold the motorcycle upright on firm level ground.
2. Remove the oil fill hole cap and O-ring.
3. Check the oil level. It should be flush with the lower edge of the oil fill hole.

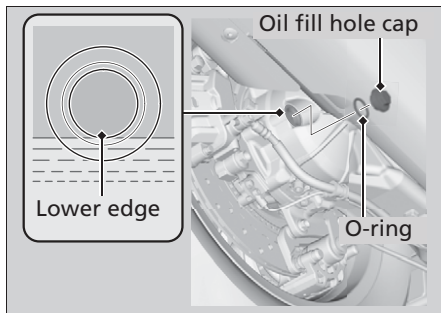

### Adding Final Drive Oil

If the final drive oil level is low, check for oil leaks. Add the recommended final drive oil (➤ P. 149) until it reaches the lower edge of the opening.

1. Pour the final drive oil into the oil fill hole until it reaches the lower edge of the opening.
  - ▶ Do not over fill above the lower edge of oil fill hole.
  - ▶ Make sure no foreign objects enter the oil fill hole.
  - ▶ Wipe up any spills immediately.
2. Install a new O-ring onto the oil fill hole cap. Tighten the oil fill hole cap.

**Torque:** 5.9 lbf-ft (8 N·m, 0.8 kgf·m)

### Changing Final Drive Oil

1. Hold the motorcycle upright on firm level ground.
2. Place a drain pan under the drain bolt.
3. Remove the oil fill hole cap, O-ring, drain bolt, and sealing washer to drain the oil.

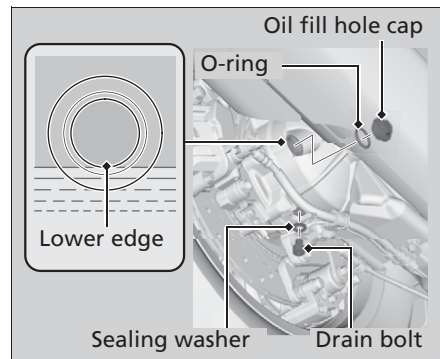

4. Install a new sealing washer onto the drain bolt. Tighten the drain bolt.
- Torque:** 9 lbf-ft (12 N·m, 1.2 kgf·m)
5. Fill the final gear with the recommended oil. ➤ P. 149
- Required oil:** 4.7 US oz (140 cm<sup>3</sup>)
6. Check the oil level. It should be flush with the lower edge of the oil fill hole.
  7. Install a new O-ring onto the oil fill hole cap. Tighten the oil fill hole cap.

**Torque:** 5.9 lbf-ft (8 N·m, 0.8 kgf·m)

8. Check that there are no oil leaks.