

Brakes

The hydraulic braking systems on your motorcycle dissipate the heat generated by the friction of the brake pads on the brake discs as the wheels are slowed.

As the brake pads wear, the brake fluid level will drop. A leak in the system will also cause the level to drop.

Frequently inspect the system to ensure there are no fluid leaks. Periodically inspect the brake fluid level and the brake pads for wear.

If the brake lever or brake pedal freeplay does not feel within the normal range while riding, check the brake pads for wear (page 199). Worn pads should be replaced. If the pads are not worn beyond the recommended limit, there is probably air in the brake system. See your dealer to have the air bled from the system.

Front Brake Lever Adjustment

Refer to *Safety Precautions* on page 154.

The distance between the tip of the brake lever and the grip may be adjusted.

RIGHT HANDLEBAR

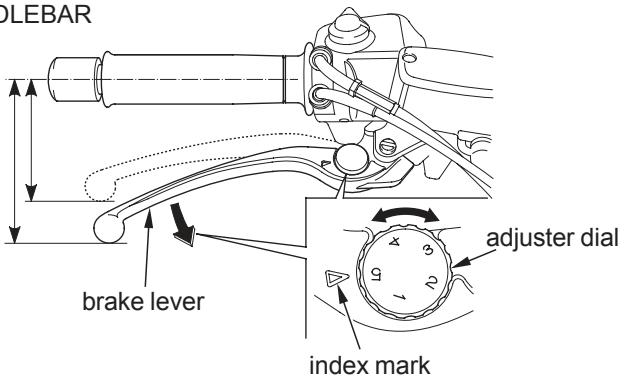

1. Turn the adjuster dial while pushing the brake lever forward.
2. Align the index mark on the brake lever with the numbers on the adjuster dial.
3. Apply the brake, release it, then spin the wheel and check that it rotates freely. Repeat this procedure several times.