

Rear Wheel

Removal

1. Support your motorcycle securely and raise the rear wheel off the ground using a maintenance stand or a hoist.
2. **NC700XD only**
Release the parking brake.
3. **NC700XD only**
Remove the mounting bolts and remove the parking brake caliper.

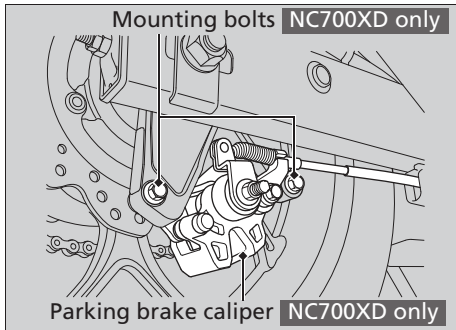

4. Loosen the rear axle nut, lock nuts and turn the adjusting nuts so the rear wheel can be moved all the way forward for maximum drive chain slack.
5. Remove the rear axle nut.

