

Suspension

Rear Suspension Adjustment (SXS1000M3L/M5L only)

The rear suspension can be adjusted for rear passengers, carrying heavier cargo by changing the damping.

Do not attempt to disassemble, service, or dispose of the damper; see your dealer. The instructions found in this owner's manual are limited to adjustments of the shock assemblies.

Rear Suspension Damping (SXS1000M3L/M5L only)

Refer to *Safety Precautions* on page 123.

REAR

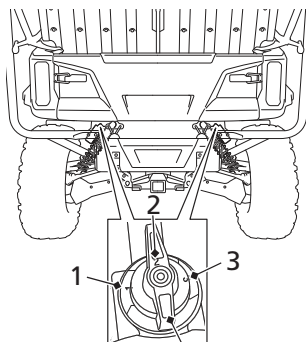

damping adjuster

The damping adjuster has 3 positions for different load or driving conditions.

Position 1: use in low payload conditions at low speeds.

Position 2: standard position.

Positions 3: use in high payload conditions such as 5 passenger loading, and/or at higher speeds.

Make sure that both shock absorbers are adjusted to the same position.