

F-11
REAR WHEEL

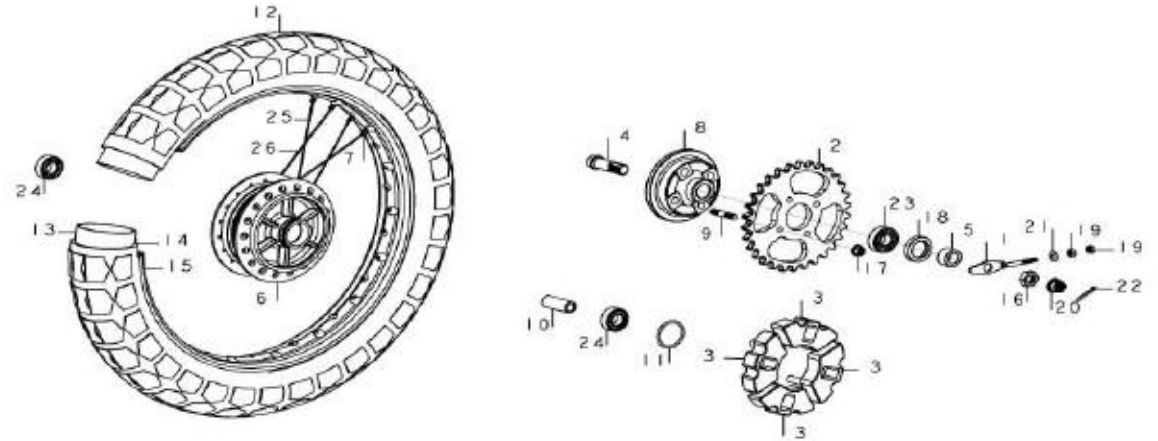

Service Item	F.R.T.	BOM Of Group Number: F-11 Model :: Splendor (Dec, 1993)			
		Ref No.	Part Number	Description	Req.
SPROCKET, FINAL DRIVEN (44T)	0.7	1	40544-198-900	ADJUSTER, 'L' CHAIN	1
DAMPER, RR .WHEEL (ONE OR ALL)	--	2	41201-KCC-900	SPROCKET, FINAL DRIVEN (42T)	1
COLLAR, RR. AXLE DISTANCE	--	3	41241-GB4-770	DAMPER, RR .WHEEL	4
BEARING, RADIAL BALL, 6301U (ADD 0.1 FOR EACH)	--	4	42303-GBG-900	SLEEVE, RR. WHHEL	1
SLEEVE, RR. WHHEL	0.5	5	42304-198-900	COLLAR, RR.AXLE SLEEVE	1
HUB, RR. WHEEL (NH-35M)	2.5	6	42601-198-900	HUB, RR. WHEEL (NH-35M)	1
FLANGE, FINAL DRIVEN	0.8	7	42603-198-900	NIPPLE, SPOKE-9	36
TYRE, RR (3.0 X 18 - 6PR)	0.9	8	42610-198-900	FLANGE, FINAL DRIVEN	1
TUBE, WHEEL	--	9	42615-198-900	BOLT, STUD., 8 X 42	4
RIM, WHEEL (1.60 X 18)	2.3	10	42620-198-900	COLLAR, RR AXLE DISTANCE	1
BEARING, RADIAL BALL, 6203	0.6	11	42653-001-000	O-RING 40.5 X 3	1
		12	42711-KCC-905	TYRE, RR (3.0 X 18 - 6PR)	1
		13	42712-P11-000	TUBE, TYRE (2.75-3.0 X 18)	1
		14	42713-198-900	FLAP, TYRE (1.40-18)	1
		15	44701-GE6-750	RIM, WHEEL (1.60 X 18)	1
		16	90307-001-000	NUT ,RR. AXLE SLEEVE	1
		17	90309-357-000	NUT, HEX .,8MM	4
		18	90753-029-000	OIL SEAL, 27 X 40 X 6	1
		19	94001-06000-0S	NUT, HEX., 6 MM	2
		20	94011-12000	NUT, CASTLE, 12 MM	1