

J 9

F-28

Outils

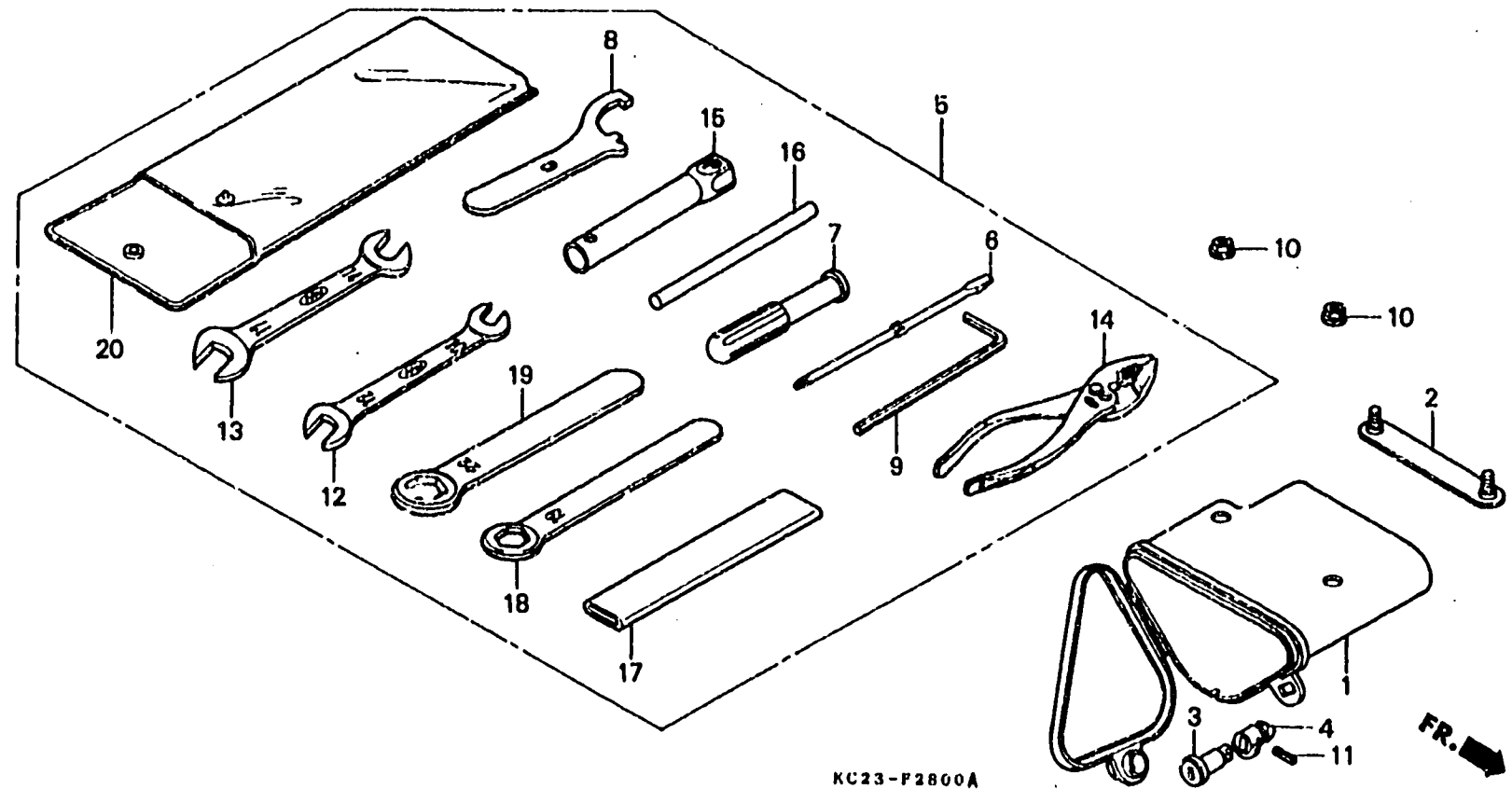

Item d'entretien	T.D.R.	N° de réf.	N° de pièce	Description	N° de requis CM125					N° de série	Code de zone	
					CC	CF	CJ	CN	CP			CR
BOITIER D'OUTILS .CORPS DE CLEF	0.2	1	83501-KB4-000	BOITIER D'OUTILS	1	1	-	1	-	1	1	1
		2	83503-471-000	PLAQUE DE FIXATION DE BOITIER	1	1	-	1	-	1	1	1
		3	83507-438-000	CORPS DE CLEF	1	1	-	1	-	1	1	1
		4	83508-438-000	BUTEE DE CORPS DE CLEF	1	1	-	1	-	1	1	1
		5	89010-KB4-000	JEU D'OUTILS	1	1	-	1	-	1	1	1
		6	89102-538-000	TIGE DE TOURNEVIS	1	1	-	1	-	1	1	1
		7	89103-538-000	POIGNEE	1	1	-	1	-	1	1	1
		9	89221-371-C00	CLE HEX. 6MM	1	1	-	1	-	1	1	1
		10	94050-06080	ECROU DE BRIDE, 6MM	2	2	-	2	-	2	2	2
		11	94305-20141	GOUILLE DE RESSORT, 2X 14	1	1	-	1	-	1	1	1
		12	99001-10120	CLE, 10X 12	1	1	-	1	-	1	1	1
		13	99001-14170	CLE, 14X 17	1	1	-	1	-	1	1	1
		14	99002-13500	PINCES, 135	1	1	-	1	-	1	1	1
		15	99004-16170	CLE A DOUILLE, P 16X 17	1	1	-	1	-	1	1	1
		16	99005-01000	BARRE A DE POIGNEE	1	1	-	1	-	1	1	1
		17	99006-12000	POIGNEE DE CLE A OEIL, 120MM	1	1	-	1	-	1	1	1
		18	99006-19000	CLE A OEIL, 19MM	1	1	-	1	-	1	1	1
		20	99008-02000	SAC D'OUTILS, 200MM	1	1	-	1	-	1	1	1