

Maintenance

Remove the pulse generator rotor cover cap.

Remove the cylinder head cover (page 8-2)

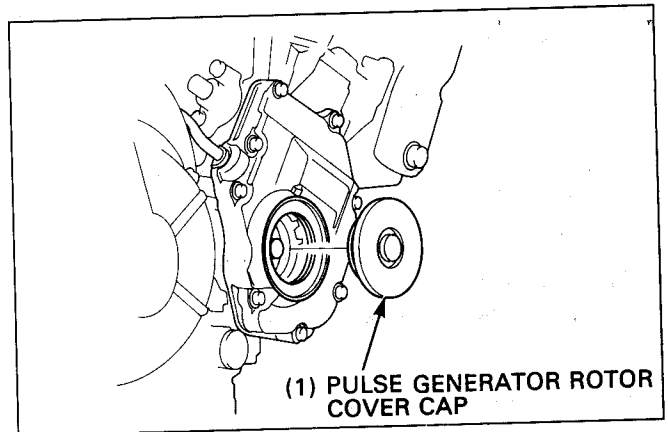

Align the T mark (notch mark) with the index mark on the pulse generator rotor cover by turning the crankshaft clockwise.

Make sure that the timing marks ("IN" and "EX") on the camshaft gears are aligned with the cylinder head upper surface facing opposite each other.

If the timing marks ("IN" and "EX") on the camshaft gears face each other, turn the crankshaft clockwise one full turn (360°) and realign the T mark (notch mark) with the index mark on the pulse generator rotor cover.

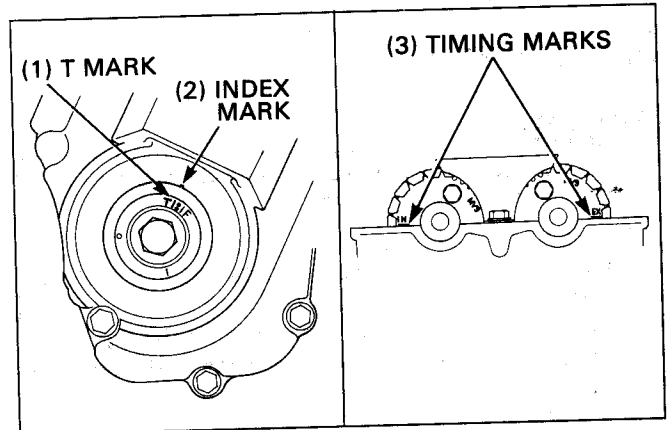

Insert a feeler gauge between the cam lobe and valve lifter at the No. 1 cylinder.

Measure and record the valve clearance.

Valve Clearances :

IN : 0.13-0.19 mm (0.005-0.007 in)

EX : 0.19-0.25 mm (0.007-0.010 in)

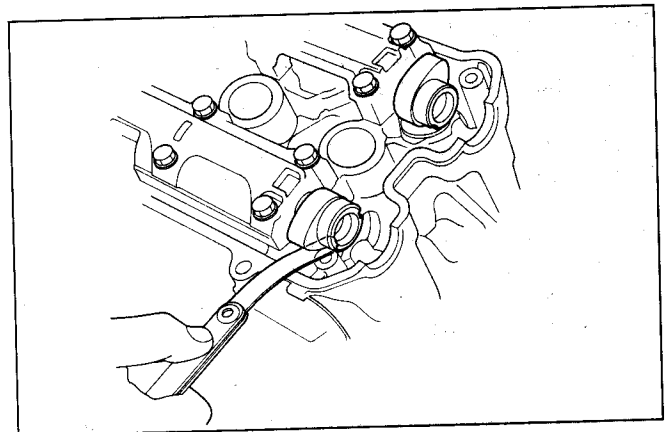

Turn the crankshaft clockwise 1/2 turn (180°) and make sure the index line on the pulse generator rotor facing top.

