

CYLINDER HEAD/VALVES

Be sure to align the dowel pins in the camshaft holder align properly with the holes in the cylinder head properly.

Install the each camshaft holder onto the camshafts.

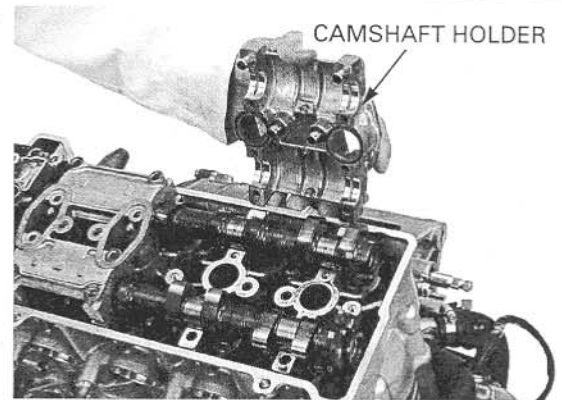

Note the correct locations with the identification marks as shown.

- No mark: right camshaft holder
- "R" mark: center camshaft holder
- "L" mark: left camshaft holder

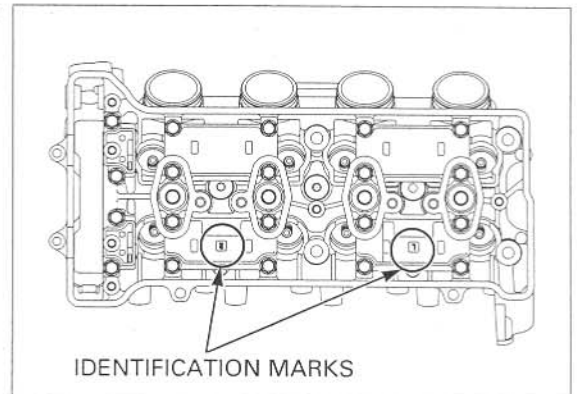

Apply engine oil to the threads and seating surfaces of the camshaft holder bolts. Install the twenty holder bolts with new eight sealing washers as shown.

Finger tighten the bolts.

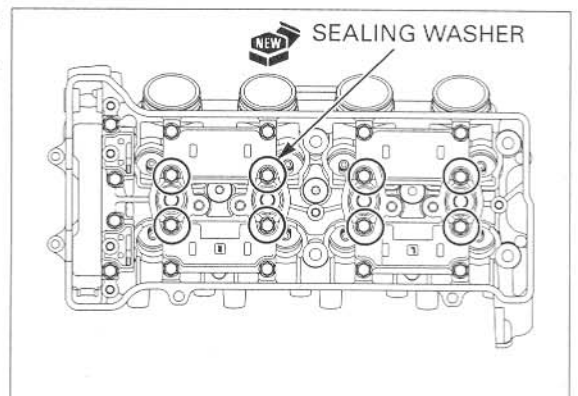

First gradually tighten the four bolts (No.5 – No.6 – No.7 – No.8) in the numerical order cast on the camshaft holders. Gradually tighten the other camshaft holder bolts until the camshaft holders lightly contact the cylinder head surface.

NOTICE

Failure to tighten the camshaft holder in a criss-cross pattern might cause a camshaft holder to break.

Tighten all camshaft holder bolts in the numerical order casted on the camshaft holders.

TORQUE: 12 N·m (1.2 kgf·m, 9 lbf·ft)

