

## CYLINDER/PISTON

Stagger the compression (1st and 2nd) and oil rings (side rails) 180 degrees apart as shown.

### NOTE

- Install the oil ring spacer first, then install the side rails.

After installation, rings should be free to rotate in the grooves.

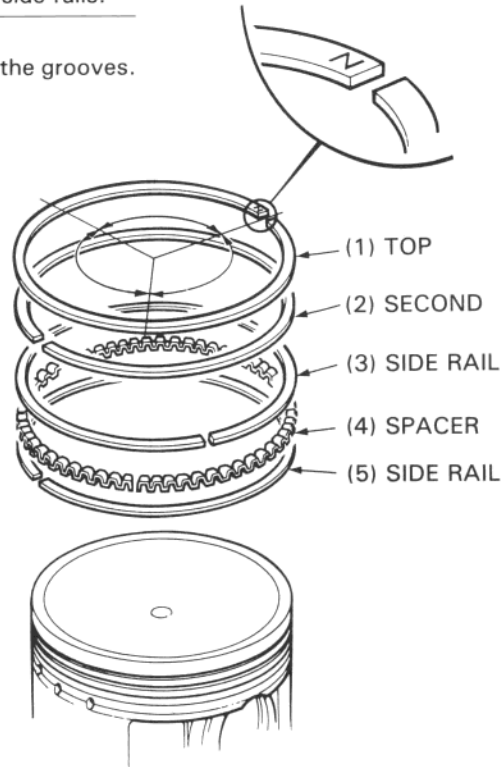

## PISTON INSTALLATION

Install the piston and piston pin. Position the piston "IN" mark on the intake valve side.

Install new piston pin clips.

### NOTE

- Do not align the piston pin clip end gap with the piston cut-out.
- Place a shop towel around the piston skirt and in the crankcase to prevent the piston pin clips from falling into the crankcase.

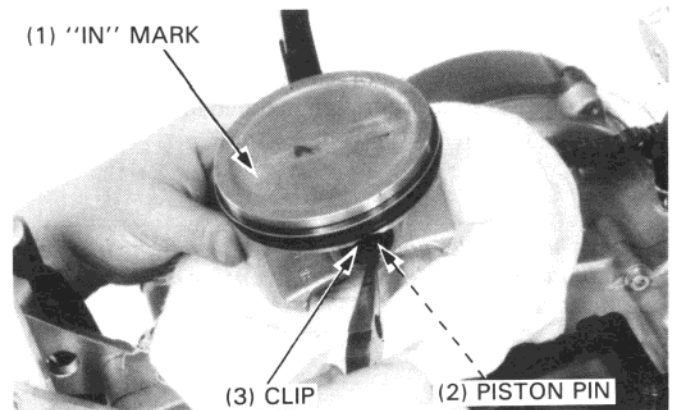

## CYLINDER INSTALLATION

Carefully clean any gasket material from the crankcase mating surface.

Apply a liquid sealant to the crankcase mating area to prevent oil leaks.

Install a new cylinder base gasket and dowel pins.

